

# Saab Rettungsdatenblätter





#### Rechtlicher Hinweis:

Diese Rettungsdatenblätter dienen der ausschließlichen Orientierung entsprechend ausgebildeter Rettungskräfte im Rahmen technischer Hilfeleistung an Saab-Fahrzeugen nach Verkehrsunfällen. Die Rettungsdatenblätter beziehen sich ausschließlich auf die Technologie von Fahrzeugen, die zum Verkauf in der Europäischen Union bestimmt sind. Die Technologie von Fahrzeugen anderer Märkte und hierin nicht aufgeführter Modellreihen kann abweichen; die Rettungsdatenblätter sind für solche Fahrzeuge daher aus Sicherheitsgründen nicht anwendbar. Die Datenblätter enthalten weiterhin keine grafischen Darstellungen zu Rechtslenkerfahrzeugen.

Änderungen der Technik, Ausstattung und Form der Fahrzeuge gegenüber den Angaben und Abbildungen in diesen Rettungsdatenblättern sowie Änderungen dieser Rettungsdatenblätter selbst bleiben vorbehalten.

Fahrzeugnutzer entnehmen detaillierte Informationen zur Funktionsweise ihres Fahrzeuges der fahrzeugeigenen Betriebsanleitung. Werkstätten und Händler erhalten technische Informationen über die ihnen bekannten Bezugsquellen.

Copyright 2009 Saab Deutschland GmbH  
Rüsselsheim, Germany

Die Erstellung der Rettungsdatenblätter und ihre Bereitstellung erfolgte mit freundlicher Unterstützung



der Firma Moditech Rescue Solutions, NL

#### ALLE RECHTE VORBEHALTEN

Die Vervielfältigung jeglicher Art, Übersetzung oder Verleihung, Vermietung oder Verkauf dieses Dokuments, im Ganzen oder zum Teil, ist nur mit vorheriger schriftlicher Genehmigung von Saab Deutschland GmbH erlaubt. Alle in diesem Dokument enthaltenen Informationen, Abbildungen und Spezifikationen stützen sich auf die zuletzt veröffentlichten Informationen, die zum Zeitpunkt der Veröffentlichung dieses Dokuments zur Verfügung standen. Die Saab Deutschland GmbH behält sich vor, Änderungen zu jeder Zeit und ohne vorherige Ankündigung vorzunehmen.



Modellbezeichnung                      Baujahr

---

### 9-3

- **9-3**
    - 9-3 4-Türer                      2002 →
    - 9-3 Cabrio                      2003 →
    - 9-3 Kombi (SportCombi)      2005 →
- 

### 9-5

- **9-5**
  - 9-5 4-Türer                      2005 →
  - 9-5 Kombi (SportCombi)      2005 →

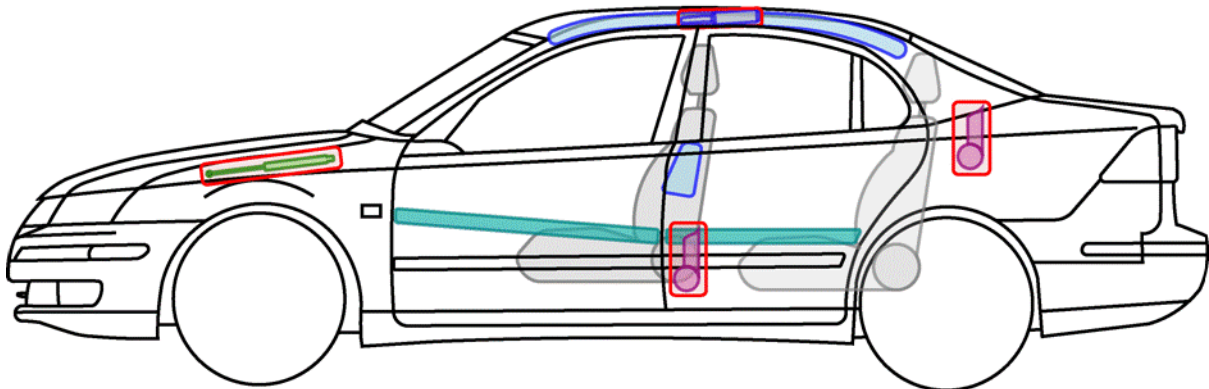
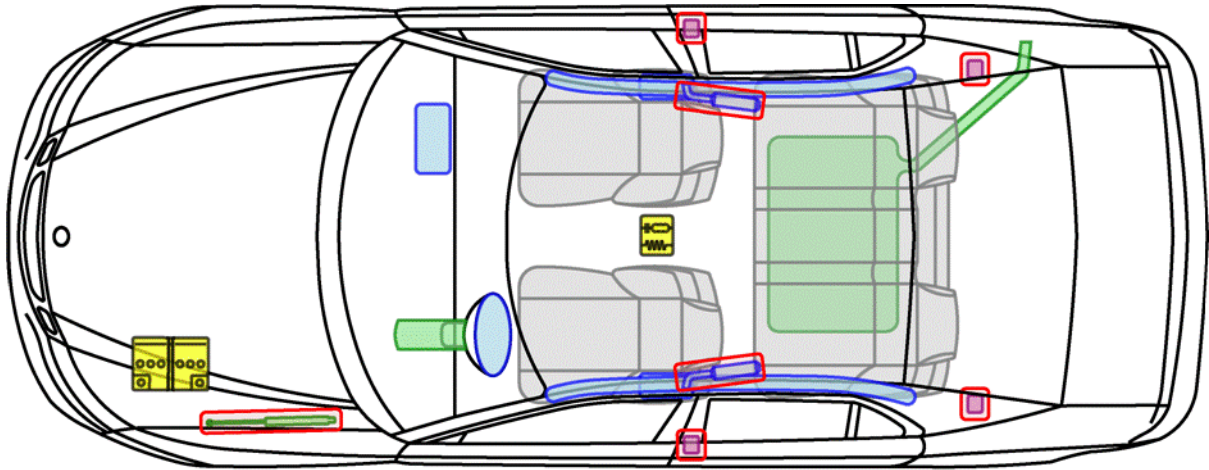

**Legende**

	<b>Airbag</b>		<b>Karosserie- verstärkung</b>		<b>Steuergerät</b>
	<b>Gas- generator</b>		<b>Überroll- schutz</b>		<b>Batterie</b>
	<b>Gurt- straffer</b>		<b>Gasdruck- dämpfer</b>		<b>Kraftstoff- tank</b>

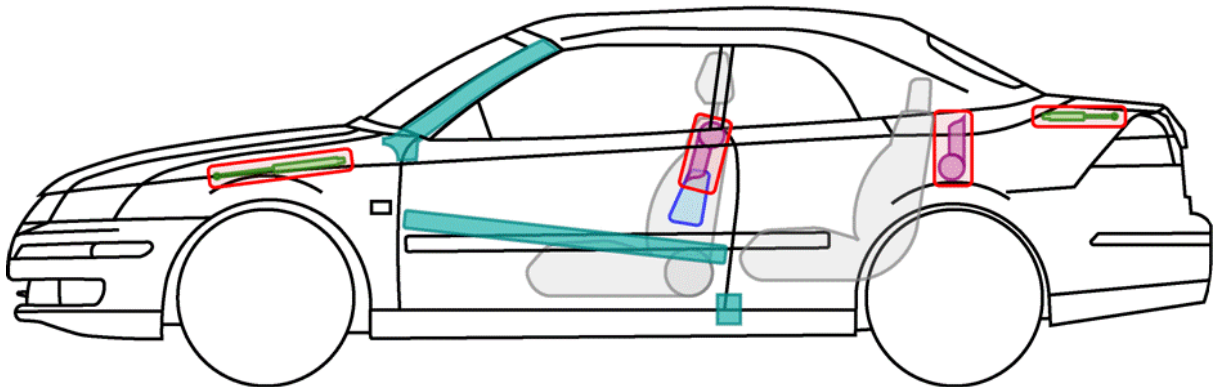
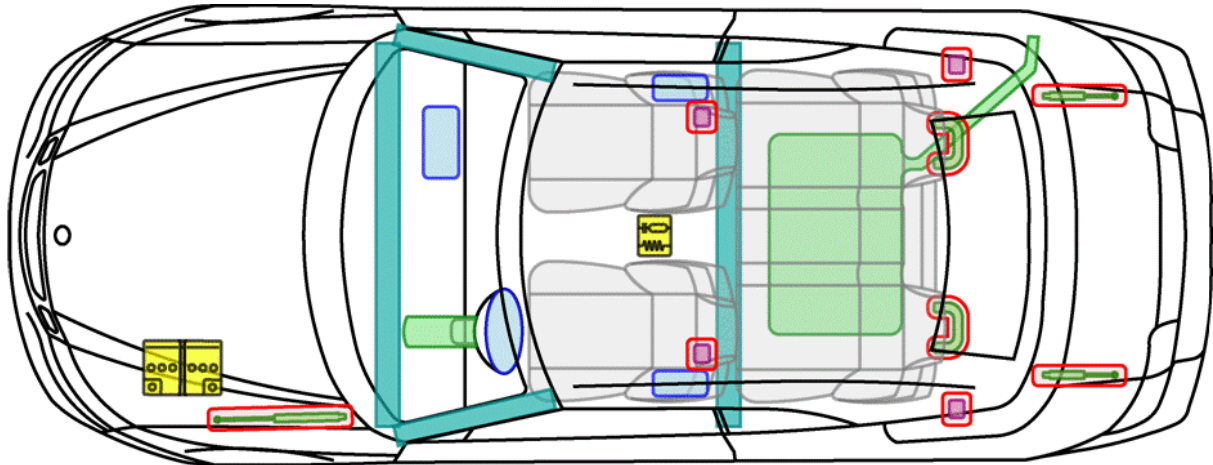

**Legende**

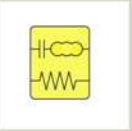
	<b>Airbag</b>		<b>Karosserie- verstärkung</b>		<b>Steuergerät</b>
	<b>Gas- generator</b>		<b>Überroll- schutz</b>		<b>Batterie</b>
	<b>Gurt- straffer</b>		<b>Gasdruck- dämpfer</b>		<b>Kraftstoff- tank</b>

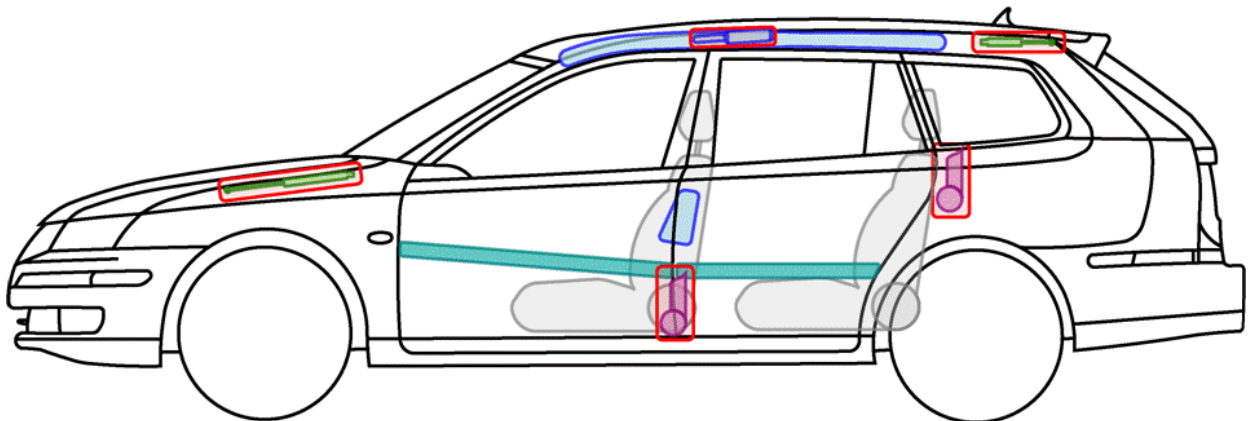
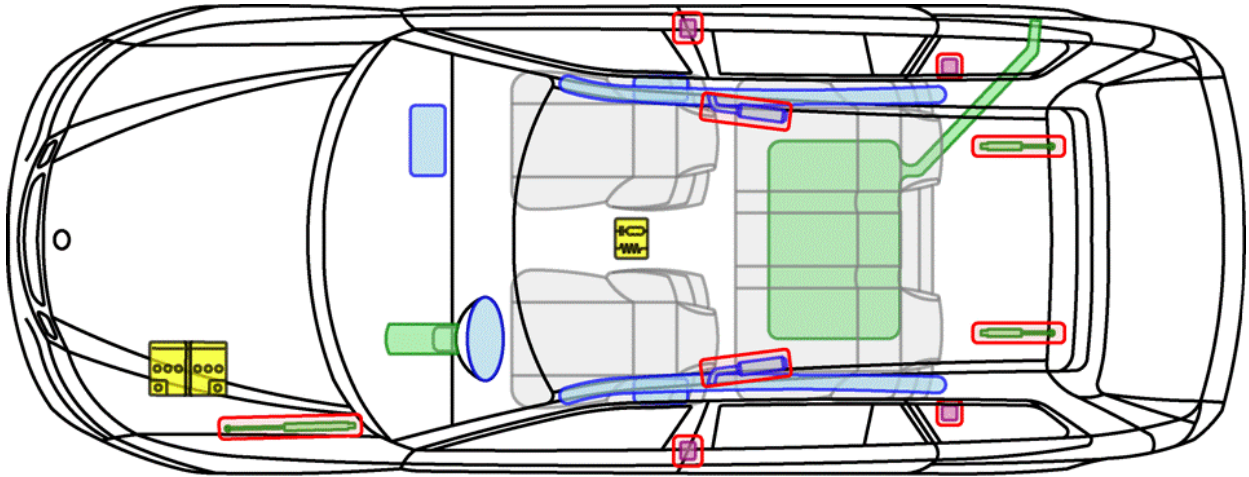

**Legende**

	<b>Airbag</b>		<b>Karosserie- verstärkung</b>		<b>Steuergerät</b>
	<b>Gas- generator</b>		<b>Überroll- schutz</b>		<b>Batterie</b>
	<b>Gurt- straffer</b>		<b>Gasdruck- dämpfer</b>		<b>Kraftstoff- tank</b>

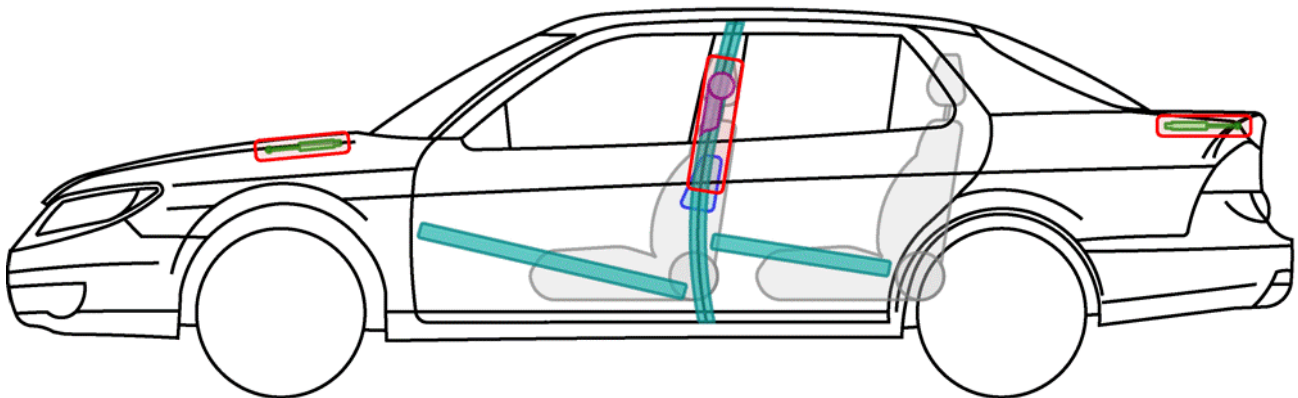
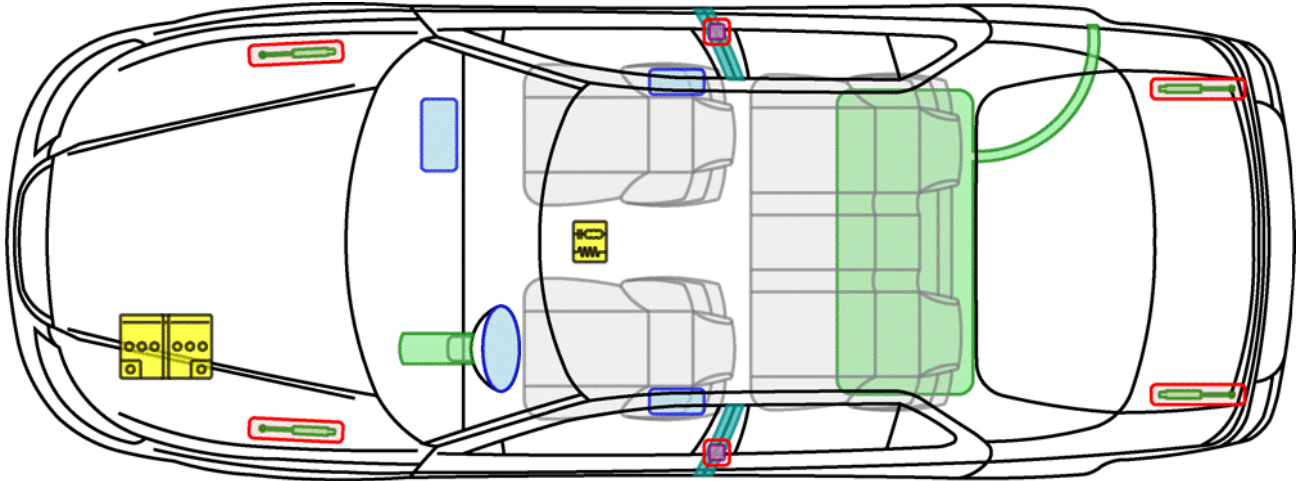

**Legende**

	<b>Airbag</b>		<b>Karosserie- verstärkung</b>		<b>Steuergerät</b>
	<b>Gas- generator</b>		<b>Überroll- schutz</b>		<b>Batterie</b>
	<b>Gurt- straffer</b>		<b>Gasdruck- dämpfer</b>		<b>Kraftstoff- tank</b>

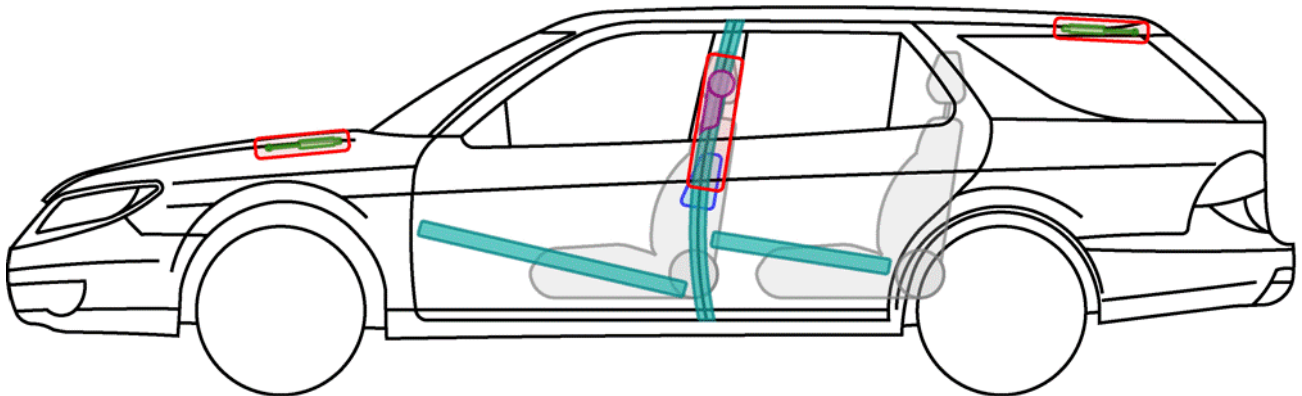
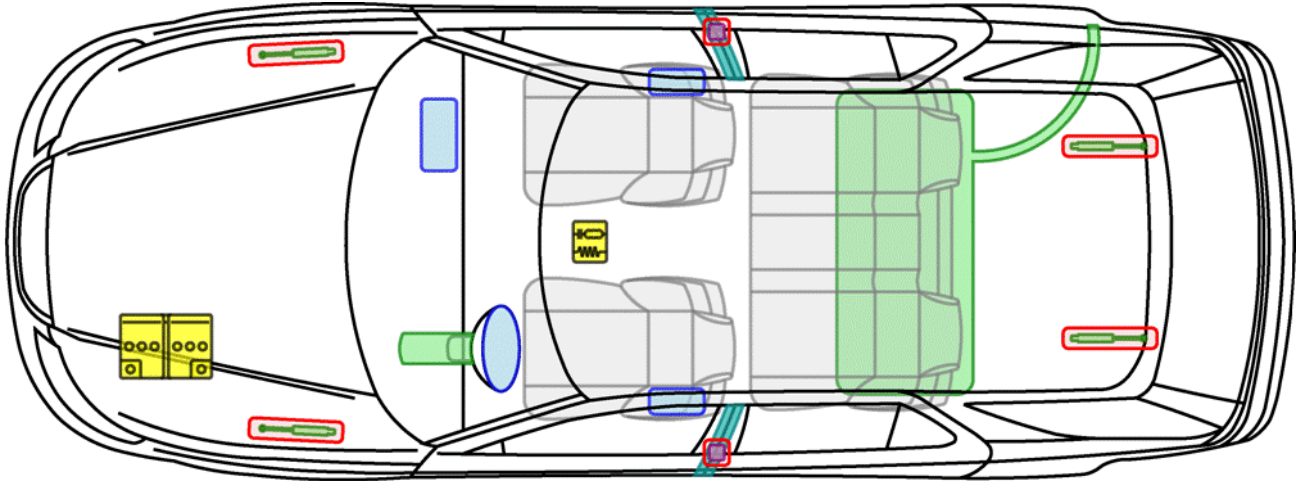

**Legende**

	<b>Airbag</b>		<b>Karosserie- verstärkung</b>		<b>Steuergerät</b>
	<b>Gas- generator</b>		<b>Überroll- schutz</b>		<b>Batterie</b>
	<b>Gurt- straffer</b>		<b>Gasdruck- dämpfer</b>		<b>Kraftstoff- tank</b>