

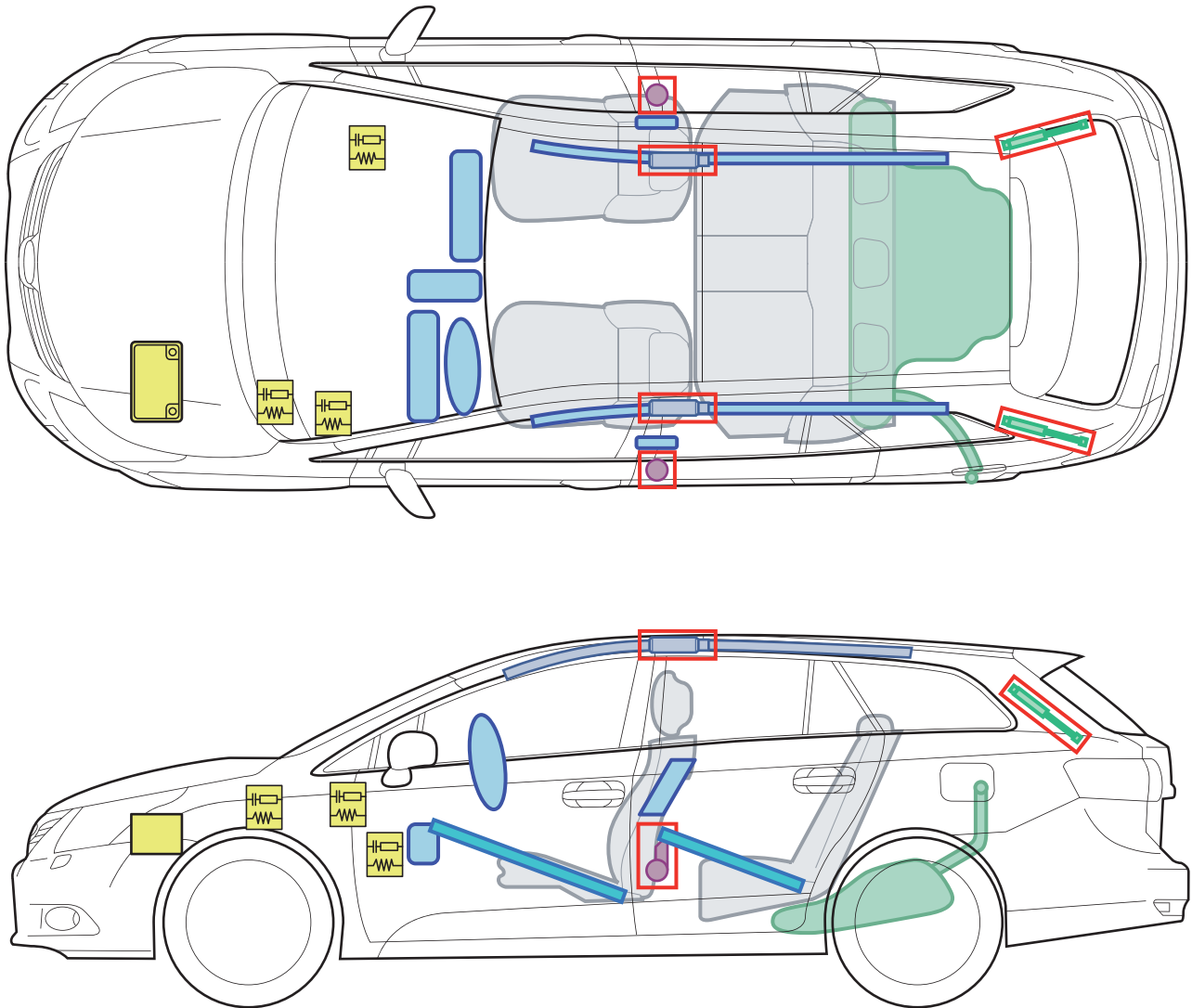

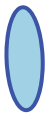





Toyota Avensis

(T27 Wagon 5-Türer, ab 2008)



Legende

	Airbag		Karosserie- verstärkung		Steuergerät
	Gas- generator		Gasdruck- dämpfer		12 Volt- Batterie
	Gurtstraffer		Kraftstoff- tank		

A







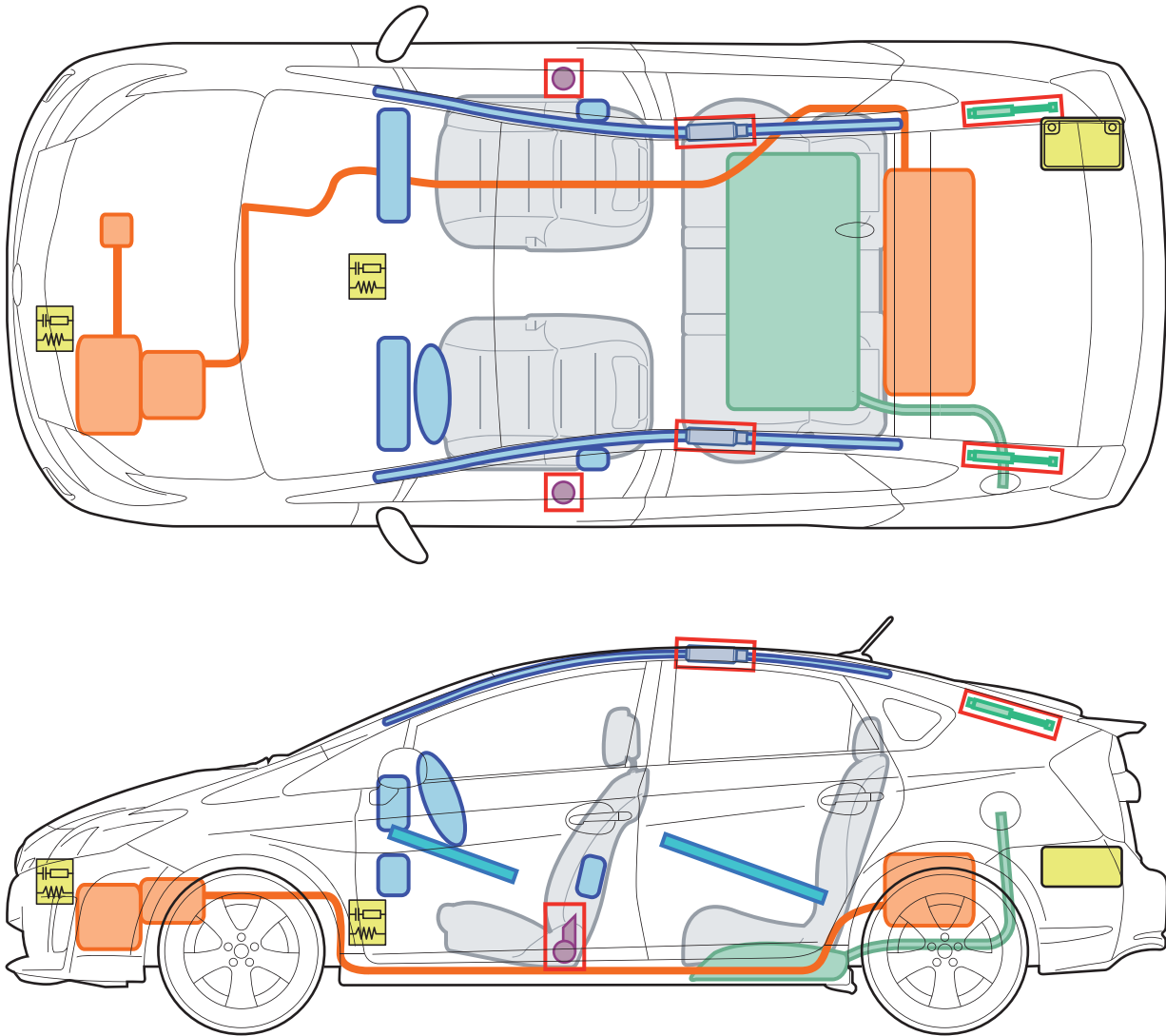

Toyota Avensis (T27 Wagon 5-Türer)

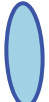
Toyota Prius

(XW3 Hybrid 5-Türer, ab 2009)



Legende

	Airbag		Karosserie- verstärkung		Steuergerät
	Gas- generator		Gasdruck- dämpfer		12 Volt- Batterie
	Gurtstraffer		Kraftstoff- tank		Hochvolt- bauteile



Besonderheiten:

Hochvoltanlage mit Gleichspannung bis 210 Volt und Wechselspannung bis 650 Volt! Hochvoltbauteile nicht berühren.
Erkennungsmerkmale und Details, siehe Rückseite!

A

Toyota Prius (XW3 Hybrid 5-Türer)

Erkennungsmerkmale:

- Schriftzug „HYBRID SYNERGY DRIVE“ auf der Heckklappe.
- Schriftzug am Motor.

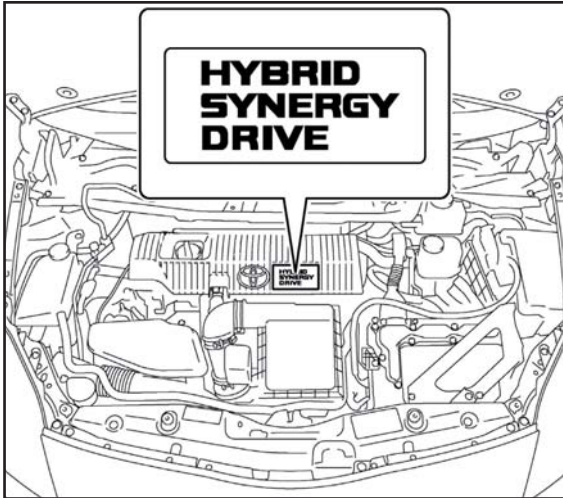

	<p>Anmerkungen: Bei Unfällen mit ausgelöstem Airbag ist die Hochvoltanlage spannungsfrei.</p> <ul style="list-style-type: none"> • Zündung ausschalten. • 12 Volt-Batterie: Minus-Pol trennen. <p>Bei Unfällen mit nicht ausgelöstem Airbag.</p> <ul style="list-style-type: none"> • Zündung ausschalten. • 12 Volt-Batterie: Minus-Pol trennen.
--	---

	<p>Lebensgefahr! Hochvoltbauteile nicht berühren!</p>
--	---





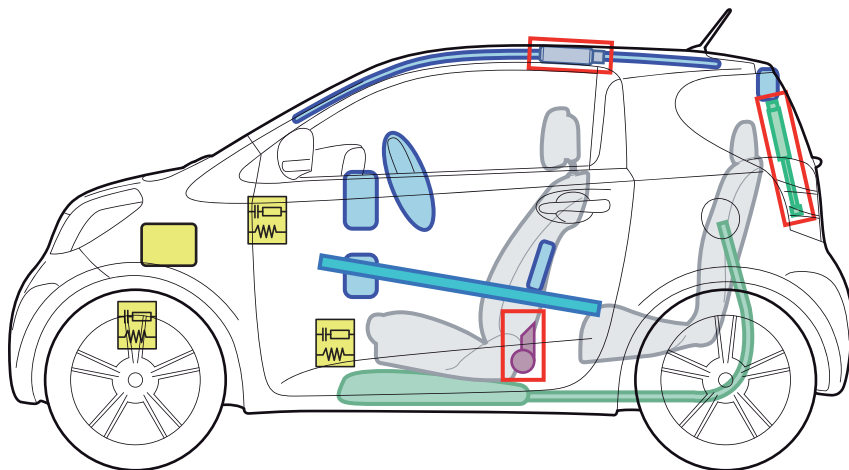
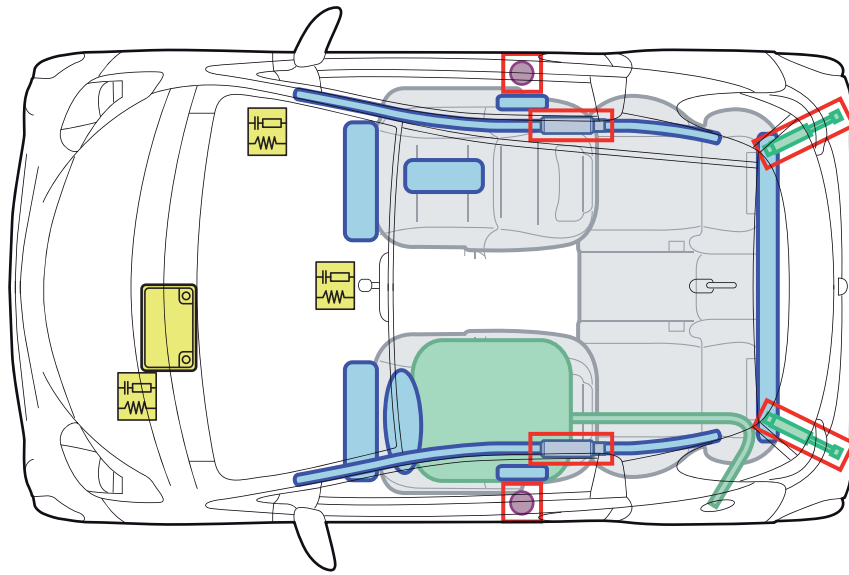

Die Hochvoltbatterie befindet sich unter der Gepäckraumverkleidung.
 Kennzeichnung der Hochvoltbatterie:

<p>⚠ DANGER       </p>	
<p>HOCHSPANNUNG / ALKALISCHES ELEKTROLYT</p>	
<p>Um Verletzungen, Verbrennungen oder Elektroschock zu vermeiden:</p> <ul style="list-style-type: none"> • Zerlegen Sie niemals diese Batterie und entfernen Sie auch nicht die Gehäusedeckel! - Service nur von qualifizierten Technikern - • Vermeiden Sie den Kontakt von alkalischem Elektrolyt mit Augen, Haut oder Kleidung. Sollten Sie doch damit in Berührung kommen, spülen Sie mit Wasser und begeben Sie sich unverzüglich in ärztliche Hilfe. • Halten Sie Kinder von dieser Batterie fern. • Beschädigen Sie die Batterie nicht beim Transport mit Gabelstaplern. Hantieren Sie auch nicht mit offener Flamme und verbrennen Sie die Batterie nicht. Sollte Elektrolyt austreten, kann Hitze erzeugt werden, welche zum Brand führen kann. 	
<p>Für die qualifizierten Techniker: Gehen Sie gemäß dem Reparaturhandbuch vor, wenn Sie die Batterie warten oder erneuern.</p>	
<p>Recycling-Information für HV-Batterien:</p> <ul style="list-style-type: none"> • Transportieren Sie die Batterie stets gemäß den entsprechenden Gesetzen. • Für das Ersetzen und Entsorgen der Batterie wenden Sie sich bitte an Ihren nächsten TOYOTA-Prius-Händler. 	

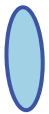
Toyota IQ (AJ1 3-Türer, ab 2009)



Legende

	Airbag		Karosserie- verstärkung		Steuergerät
	Gas- generator		Gasdruck- dämpfer		12 Volt- Batterie
	Gurtstraffer		Kraftstoff- tank		

A







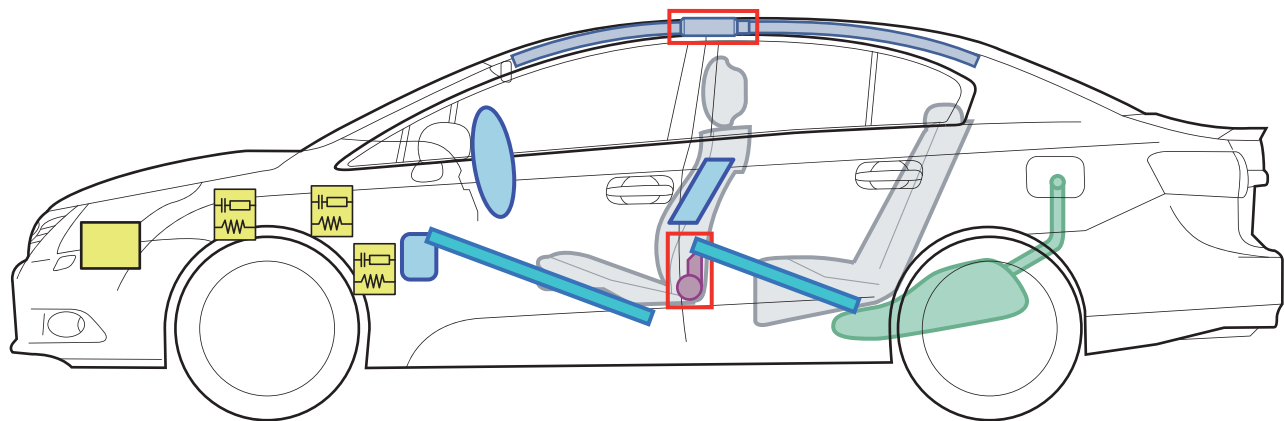
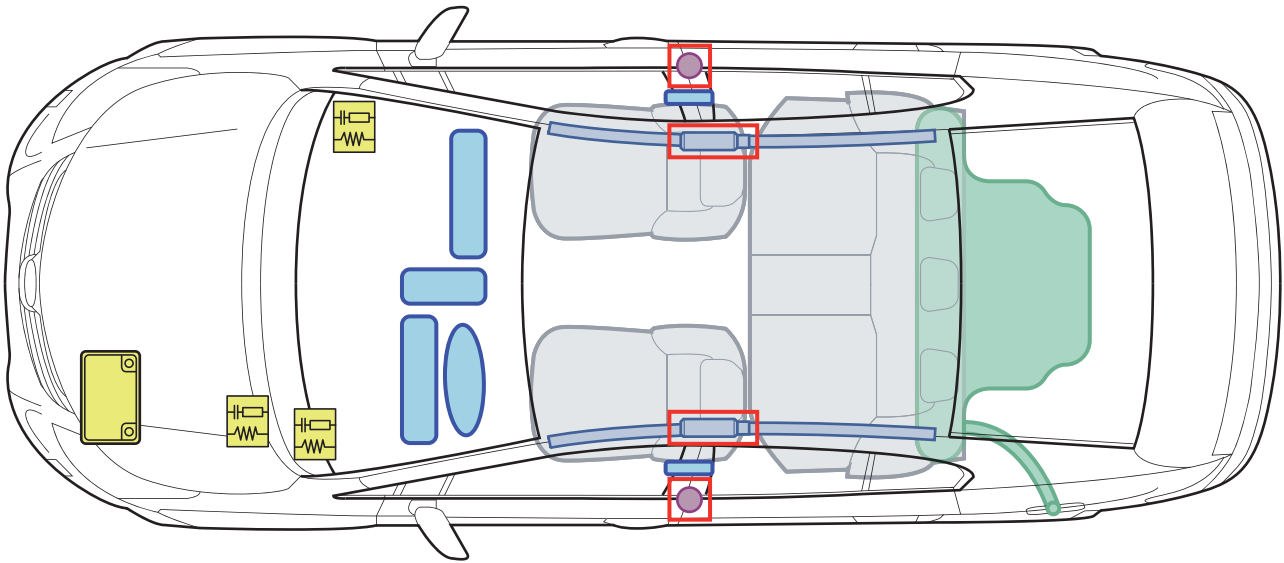

Toyota IQ (AJ1 3-Türer)

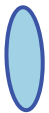
Toyota Avensis

(T27 Sedan 4-Türer, ab 2008)



Legende

	Airbag		Karosserie- verstärkung		Steuergerät
	Gas- generator		Gasdruck- dämpfer		12 Volt- Batterie
	Gurtstraffer		Kraftstoff- tank		







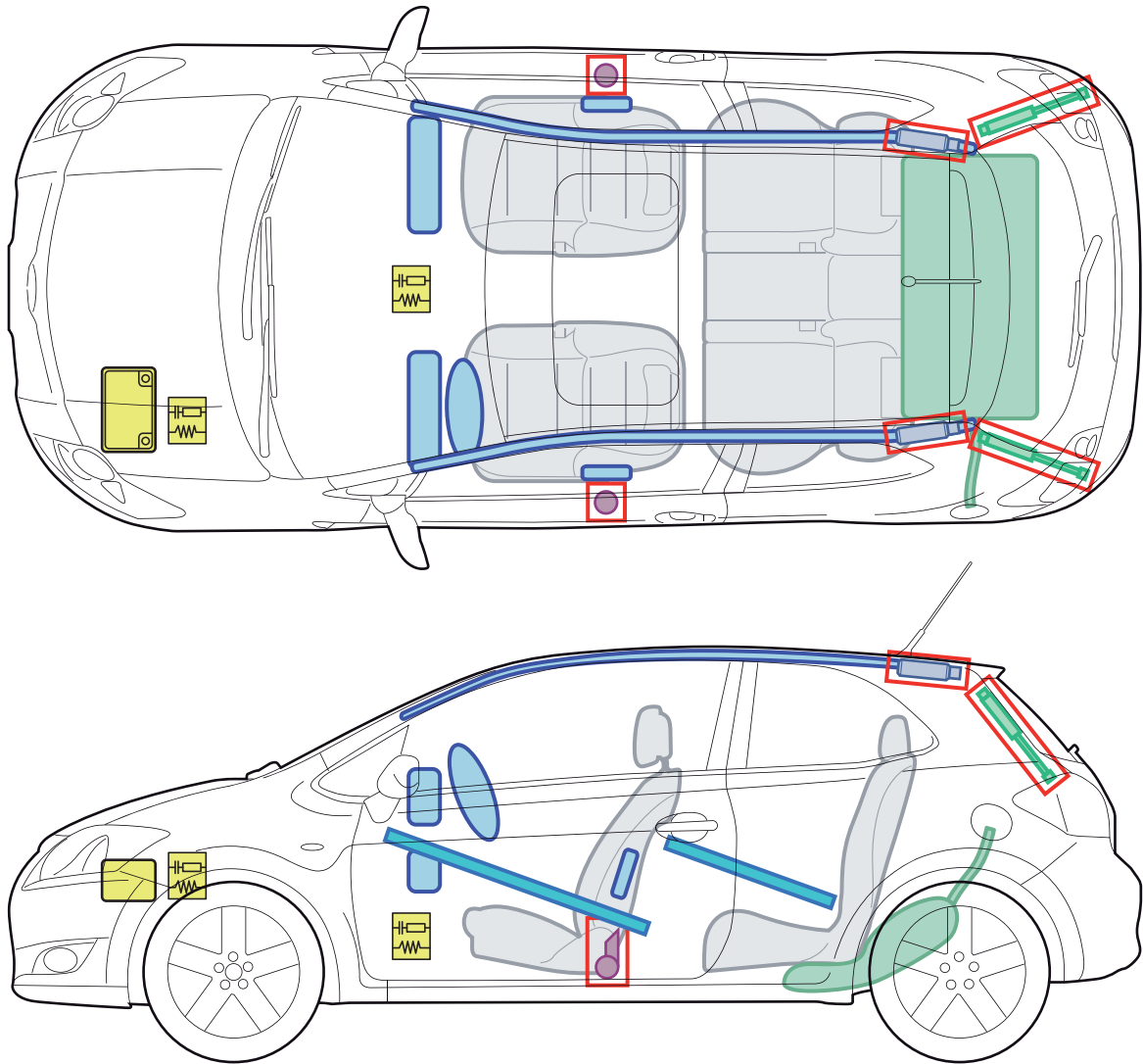

A

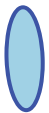
Toyota Avensis (T27 Sedan 4-Türer)

Toyota Auris (E15UT 3-Türer, ab 2009)



Legende

	Airbag		Karosserie- verstärkung		Steuergerät
	Gas- generator		Gasdruck- dämpfer		12 Volt- Batterie
	Gurtstraffer		Kraftstoff- tank		







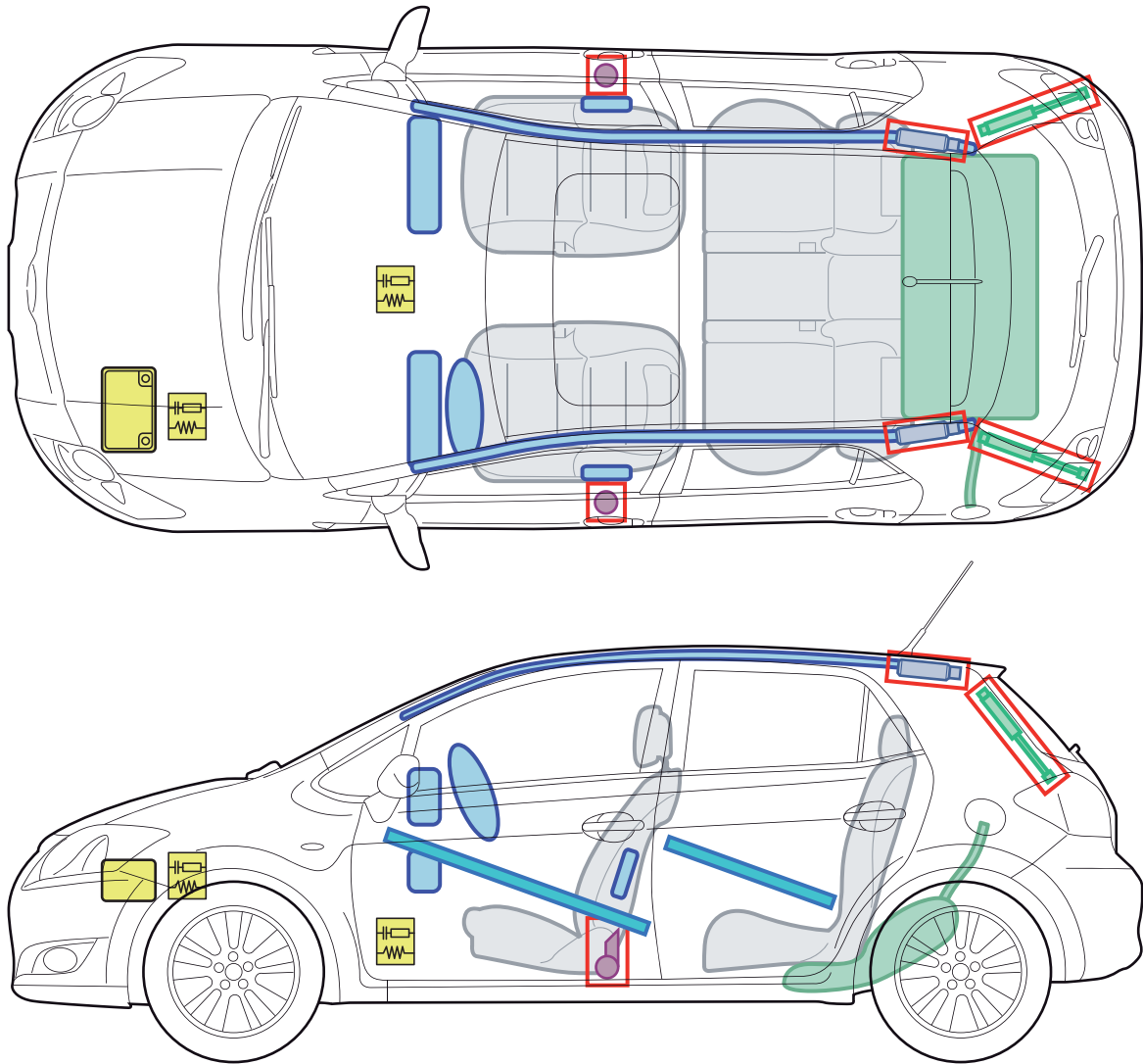

A

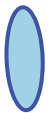
Toyota Auris (E15UT 3-Türer)

Toyota Auris (E15UT 5-Türer, ab 2009)



Legende

	Airbag		Karosserie- verstärkung		Steuergerät
	Gas- generator		Gasdruck- dämpfer		12 Volt- Batterie
	Gurtstraffer		Kraftstoff- tank		

A

Toyota Auris (E15UT 5-Türer)